



Red Line

affettatrici - slicers 

VERTICAL PRO Ø 300CR



Ø 230 mm



1.275 mm X h.230 mm



0 > 15 mm



290 mm



SCHEDA TECNICA A PAGINA 101
TECHNICAL SHEET ON PAGE 101



Blocco vela
Gauge plate lock



Coprilama integrale
Whole blade protection ring



Ampio spazio tra lama e motore
Large space between blade and motor

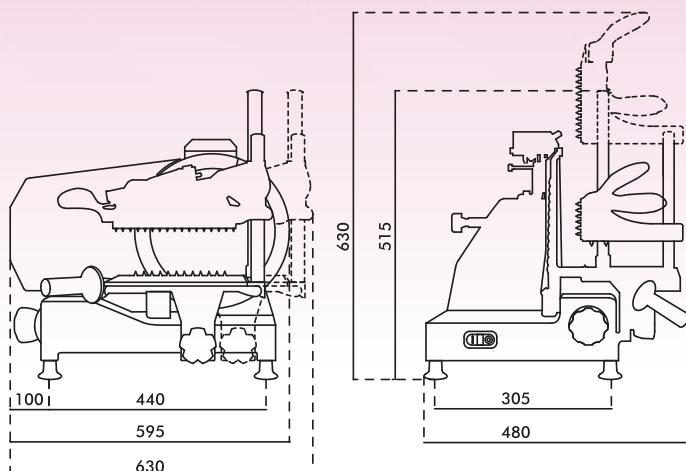

DIMENSIONI/Measures

| | |
|---|--------------------------|
| DIAMETRO LAMA Blade diameter | Ø 300 mm |
| CORSA Working stroke | 290 mm |
| DIMENSIONI PIATTO PORTA SALUMI Cold cuts tray dimensions | 260 x 270 mm |
| DIMENSIONI PIATTO PORTA FETTA Slices tray dimensions | 160 x 265 mm |
| DIMENSIONI CON IMBALLO Volume with packaging | 1.740 x p.560 x h.640 mm |
| PESO NETTO Net weight | 25,5 kg |
| PESO LORDO Gross weight | 36,5 kg |

CAPACITÀ DI TAGLIO/Cutting capabilities

| | |
|---|------------------|
| TAGLIO ROTONDO Round cut | Ø 230 mm |
| TAGLIO RETTANGOLARE Rectangular cut | 1.275 x h.230 mm |
| SPESSORE TAGLIO Manual cut thickness | 0 > 15 mm |

IMPIANTO ELETTRICO/Electric system

| | |
|--|------------------------|
| ALIMENTAZIONE Electrical supply | 187W - 230V P+N+T/50Hz |
| | 266W - 400V 3P+T/50Hz |
| COMANDI A BASSA TENSIONE (24V) Low voltage controls (24V) | ✓ |

CARATTERISTICHE/Details

| | |
|---|---|
| COPRILAMA INTEGRALE Full blade cover | ✓ |
| BLOCCO VELA Gauge plate safety lock | ✓ |
| CARRELLO ASPORTABILE Removable carriage | ✓ |
| SPAZIO LAMA Easy cleaning space between blade and engine | ✓ |
| MOTORE ASINCRONO VENTILATO Asynchronous engine | ✓ |
| TRASMISSIONE A CINGHIA POLY-V Poly-V belt transmission | ✓ |
| CORPO IN ALLUMINIO ANODIZZATO E LACCATO Anodized and lacquered aluminum body | ✓ |
| AFFILATOIO INTEGRATO Built-in blade sharpener | ✓ |