

SPIRAL 25E



Utilizzabile per pasta all'uovo
For use with egg kneading



T.C.S. System
Tendicatena con molla di ripristino
T.C.S. System
Chain adjustment with restore spring



Testa ribaltabile
Liftable head



Vasca estraibile
Extractible bowl



Timer
Timer



Doppia velocità
Double speed

3 Phase







Supporto con ruote disponibile
Available stand with wheels



Spezzapasta asportabile
Removable dough breaker bar



SCHEDA TECNICA A PAGINA 136
TECHNICAL SHEET ON PAGE 136

	DIMENSIONI INTERNE VASCA INTERNAL BOWL DIMENSIONS	
	Ø 400 x h.250 mm	
	CAPACITÀ VASCA BOWL CAPACITY	
	31 lt	
	IMBALLO CON PALLET PACKAGING WITH PALLET	
	l.800 x p.470 x h.910 mm	
	PESO NETTO NET WEIGHT	PESO LORDO GROSS WEIGHT
	98 kg	104 kg

	IMPASTO MASSIMO MAX KNEADING
	25 kg (farina/ flour max 17 kg)
	IMPASTO MINIMO MIN KNEADING
	10 kg

	PASTA ALL'UOVO FRESH EGG DOUGH
	17 kg

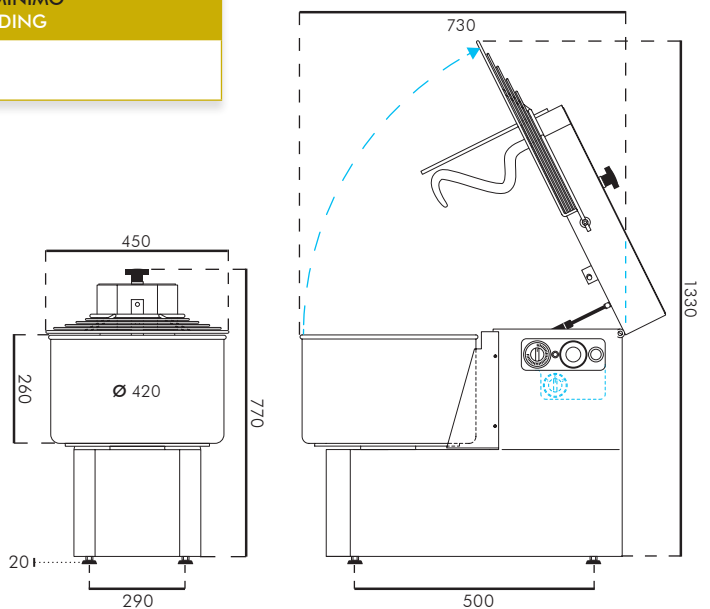

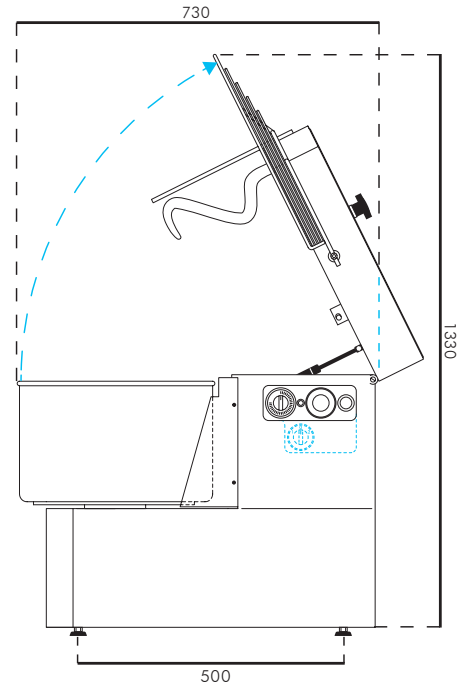
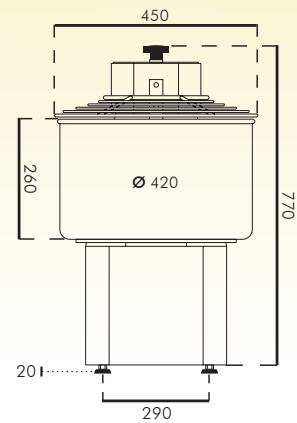
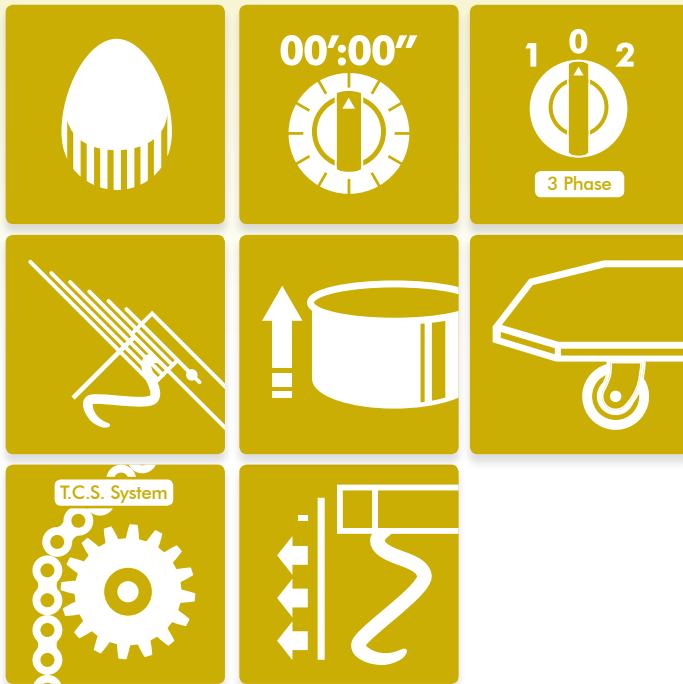

DIMENSIONI/Measures

VOLUME CON IMBALLO Volume with packaging	1.800 x p.470 x h.910 mm
DIMENSIONI INTERNE VASCA Internal bowl dimensions	Ø 400 x h.250 mm
CAPACITÀ VASCA Bowl capacity	31 lt
PESO NETTO Net weight	98 Kg
PESO LORDO Gross weight	104 Kg

CARATTERISTICHE/Details

IDEALE PER PASTA ALL'UOVO Ideal for egg pasta	✓
T.C.S. SYSTEM TENDICATENA CON MOLLA DI RIPRISTINO T.C.S. System Chain adjustment with restore spring	✓
TESTA RIBALTABILE Liftable head	✓
VASCA ESTRAIBILE Extractible bowl	✓
TIMER Timer	✓
DOPPIA VELOCITÀ Double speed	✓
CAVALLETTO CON RUOTE DISPONIBILE Available stand with wheels	✓
SPEZZAPASTA ASPORTABILE Removable dough breaker bar	✓

CAPACITÀ DI IMPASTO/Kneading capacity

IMPASTO MASSIMO Max kneading	25 kg (farina/ flour max 17 kg)	
IMPASTO MINIMO Max kneading	10 kg	
PASTA ALL'UOVO Fresh egg pasta	17 kg	
VELOCITÀ SPIRALE Spiral speed	UNA VELOCITÀ One speed	100 RPM
	DUE VELOCITÀ Two speeds	97-150 RPM
VELOCITÀ VASCA Bowl speed	UNA VELOCITÀ One speed	9 RPM
	DUE VELOCITÀ Two speeds	9-14 RPM

IMPIANTO ELETTRICO/Electric system

ALIMENTAZIONE Electrical supply	400V 3P+T/50 Hz	
	230V 3P+T/50 Hz	
	230V P+N+T/50 Hz	
POTENZA Power consumption	UNA VELOCITÀ One speed	1100 W
	DUE VELOCITÀ Two speeds	750-1100 W