

MOZZYCUT C



Realizzato in inox
Inox made



VELOCITÀ SPEEDS	140 rpm
DOTAZIONE EQUIPMENT	Espulsore alto High ejector
PRODUZIONE ORARIA OUTPUT PER HOUR	120-190 kg/h
IMBALLO CON PALLET PACKAGING WITH PALLET	l.530 x p.670 x h.660 mm
PESO NETTO NET WEIGHT	18,5 kg
PESO LORDO GROSS WEIGHT	24,5 kg

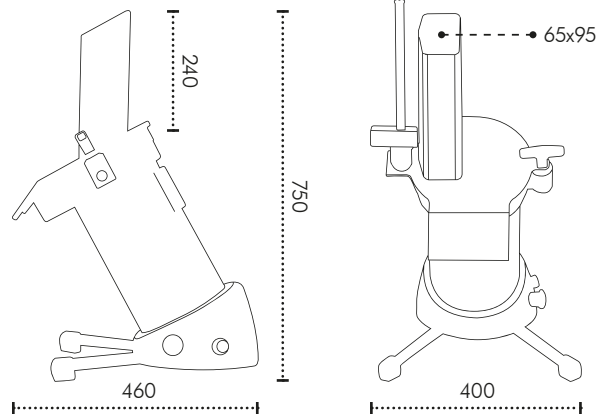

COD. APMTMC

Crea la tua configurazione/Create your own configuration

Scegli l'alimentazione elettrica (x1)/Choose the electrical power supply (x1)

 380W - 230V P+N+T/50Hz























COD. 230M

 380W - 400V 3P+T/50Hz

COD. 400T

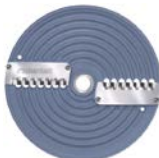
Scegli i dischi accessori/Choose the accessory disks

MOZZYCUT DISKS

MODELLO/MODEL	CODICE/CODES	DESCRIZIONE/DESCRIPTION	TAGLIO/CUT DIM.
	APN8x8x5		 8x8x5 H mm
	APN10x10x5	Disco per cubetti H 5 mm Associare a coltello APP5	 10x10x5 H mm
	APN12x12x5	Disc for cubing H 5 mm Use only with COLT 5 knife	 12x12x5 H mm
	APN16x16x5		 16x16x5 H mm
	APP5	COLTELLO H 5 mm	--
	APN8x8x8		 8x8x8 H mm
	APN10x10x8	Disco per cubetti H 8 mm Associare a coltello APP8	 10x10x8 H mm
	APN12x12x8	Disc for cubing H 8 mm Use only with COLT 8 knife	 12x12x8 H mm
	APN16x16x8		 16x16x8 H mm
	APP8	COLTELLO H 8 mm	--
	APC8x8		 8xØ 8 mm
	APC10x8	Disco per cilindretti Ø 8 mm Usare solo con disco AP2PZ8	 10xØ 8 mm
	APC12x8	Disc for cutting into cylinders Ø 8 mm Use only with AP2PZ8 disc	 12xØ8 mm
	APC16x8		 16xØ 8 mm
	AP2PZ8	Disco per spaghetture Disc to cut into spaghetti	 Ø 8 mm
	AP4PZ5	Disco per spaghetture Disc to cut into spaghetti	 Ø 5 mm
	AP4PZ8	Disco per spaghetture. Disc to cut into spaghetti	 Ø 8 mm
	AP2PZ8	Disco per spaghetture. Disc to cut into spaghetti	 Ø 8 mm
	APPZ4	Disco per sfilacciare Disc for shredding	 Ø 4 mm
	APPZ7	Disco per sfilacciare Disc for shredding	 Ø 7 mm
	APEB	Disco espulsore basso Low ejector	--
	APEA	Disco espulsore alto High ejector	--