

APLUS 700 DOPPIA PORTA 1 VANO



Realizzato in inox
Inox made



700 lt



800 mm



R404a



Spessore isolamento
Insulation thickness



Evaporazione elettrica
Electric evaporation



Tropicalizzato
Tropicalised



Guide a "L"
"L" slides



Refrigerazione ventilata
Ventilated refrigeration



Luce e serratura
Light and keylock



Guide a "C"
"C" slides



Unità cond. sostituibile
C. unit fast replacement

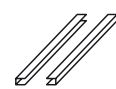

x3 coppie guida
x3 slides pair

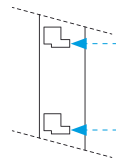

75 mm
x17 livelli
x17 positions

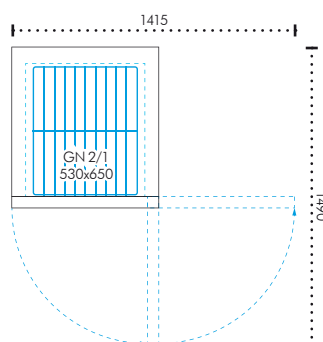
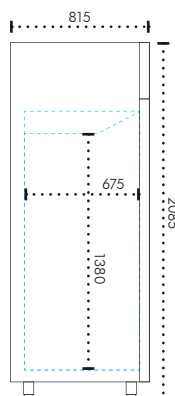
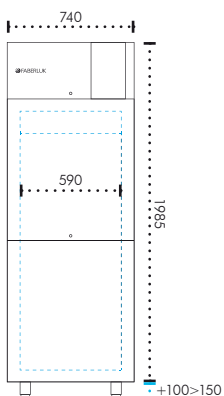

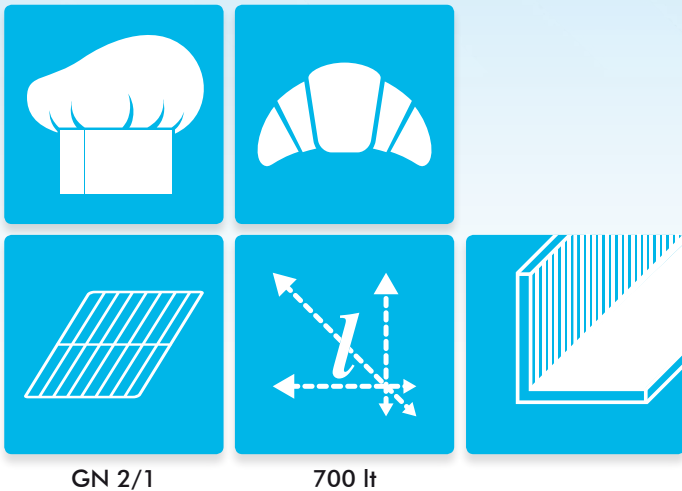

GN 2/1

700 Lt

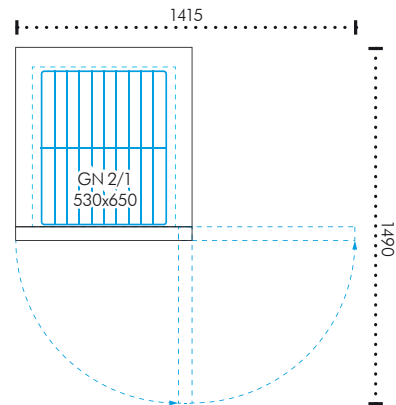
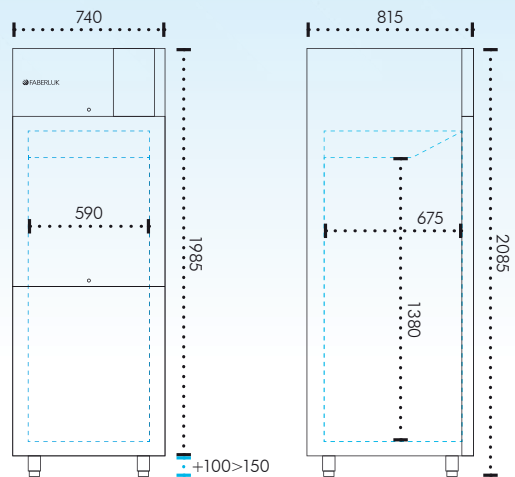

DIMENSIONI/Measures	
VOLUME CON IMBALLO Volume with packaging	1.770 x h.2140 x p.860 mm
PESO NETTO Net weight	126 kg (116 kg per Remoto)
PESO LORDO Gross weight	140 kg (130 kg per Remoto)
CAPACITÀ Capacity	700 Lt
PIEDINI INOX REGOLABILI Inox adjustable feet	100÷150 mm

CARATTERISTICHE/Details		
MATERIALE DI COSTRUZIONE Building material	ACCIAIO INOX AISI 304 AISI 304 Stainless steel	
TEMPERATURE DISPONIBILI Available temperatures	0 ÷ +8 °C -2 ÷ +8 °C -18 ÷ -22 °C	
GAS REFRIGERANTE Refrigerating gas	R404a	
REFRIGERAZIONE VENTILATA Ventilated refrigeration	✓	
SBRINAMENTO AUTOMATICO Automatic defrosting	0 ÷ +8 °C	A fermata semplice Simple stop
	-2 ÷ +8 °C	Con resistenza elettrica With electric resistor
	-18 ÷ -22 °C	Con resistenza elettrica With electric resistor
EVAPORAZIONE CONDENSA Evaporation of the condensate	Automatica con resistenza Automatic with resistor	
UNITÀ CONDENSANTE ESTRAIBILE Removable cooling unit	✓	
TROPICALIZZAZIONE Tropicalization	✓	
LUCE E SERRATURA DI SERIE Light and keylock as standard	✓	
SPESSORE ISOLAMENTO Insulation thickness	75 mm	
DISPONIBILI GUIDE INOX A "L" Inox "L" slides available	✓	
PORTE REVERSIBILI Reversible doors	✓	

IMPIANTO ELETTRICO/Electric system		
ALIMENTAZIONE Electrical supply	230V P+N+T/50 Hz	
ASSORBIMENTO Power consumption	0 ÷ +8 °C	330W
	-2 ÷ +8 °C	330W
	-18 ÷ -22 °C	850W
RESA FRIGORIFERA evap. -10 °C / cond. 54,4 °C *evap. -23,3 °C / cond. 54,4 °C Refrigeration yield	0 ÷ +8 °C	368W
	-2 ÷ +8 °C	368W
	-18 ÷ -22 °C	*782W

DOTAZIONE/Equipment	
GRIGLIE Shelves	x3 GN 2/1 rilsan 650x530 mm
COPPIA GUIDE INOX Inox slides pair	x3 a "C"