

APLUS 650 1 VANO



Realizzato in inox
Inox made



650 lt



700 mm



R404a



Spessore isolamento
Insulation thickness



Evaporazione elettrica
Electric evaporation



Tropicalizzato
Tropicalised



Guide a "C"
"C" slides



Refrigerazione ventilata
Ventilated refrigeration



Luce e serratura
Light and keylock



Porta reversibile
Reversible door



Unità cond. sostituibile
C. unit fast replacement



Sbrinamento a gas caldo
Hot gas defrost
-18 ÷ -22 °C

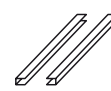

x3 coppie guida
x3 slides pair

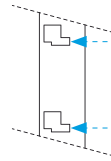

75 mm
x17 livelli
x17 positions

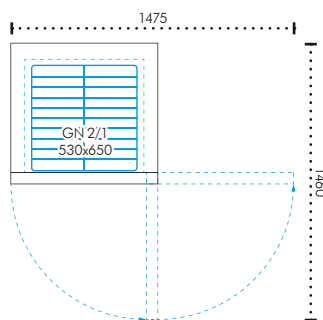
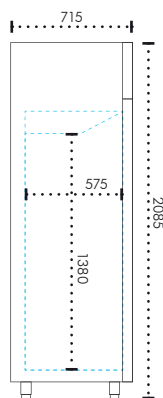
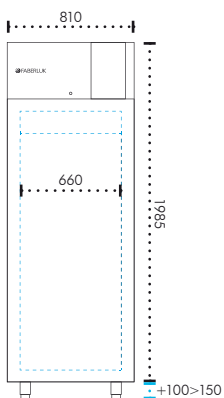

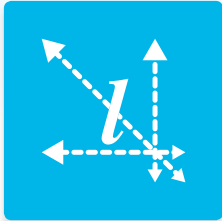
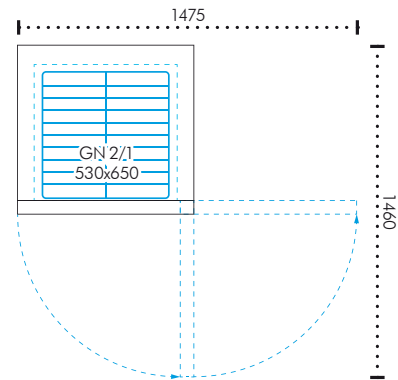
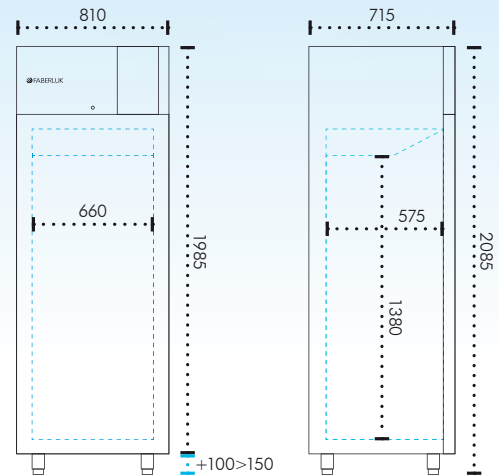
GN 2/1

650 lt

DIMENSIONI/Measures

VOLUME CON IMBALLO Volume with packaging	1.860 x h.2140 x p.770 mm
PESO NETTO Net weight	125 kg (115 kg per Remoto)
PESO LORDO Gross weight	139 kg (129 kg per Remoto)
CAPACITÀ Capacity	650 Lt
PIEDINI INOX REGOLABILI Inox adjustable feet	100÷150 mm

CARATTERISTICHE/Details

MATERIALE DI COSTRUZIONE Building material	ACCIAIO INOX AISI 304 AISI 304 Stainless steel	
TEMPERATURE DISPONIBILI Available temperatures	0 ÷ +8 °C	
	-2 ÷ +8 °C	
	-18 ÷ -22 °C	
GAS REFRIGERANTE Refrigerating gas	R404a	
REFRIGERAZIONE VENTILATA Ventilated refrigeration	✓	
SBRINAMENTO AUTOMATICO Automatic defrosting	0 ÷ +8 °C	A fermata semplice Simple stop
	-2 ÷ +8 °C	Con resistenza elettrica With electric resistor
	-18 ÷ -22 °C	A gas caldo With hot gas
EVAPORAZIONE CONDENSA Evaporation of the condensate	Automatica con resistenza Automatic with resistor	
UNITÀ CONDENSANTE ESTRAIBILE Removable cooling unit	✓	
TROPICALIZZAZIONE Tropicalization	✓	
LUCE E SERRATURA DI SERIE Light and keylock as standard	✓	
SPESSORE ISOLAMENTO Insulation thickness	75 mm	
PORTA REVERSIBILE Reversible door	✓	

IMPIANTO ELETTRICO/Electric system

ALIMENTAZIONE Electrical supply	230V P+N+T/50 Hz	
ASSORBIMENTO Power consumption	0 ÷ +8 °C	650W
	-2 ÷ +8 °C	650W
	-18 ÷ -22 °C	1100W
RESA FRIGORIFERA evap. -10 °C / cond. 54,4 °C *evap. -23,3 °C / cond. 54,4 °C Refrigeration yield	0 ÷ +8 °C	668W
	-2 ÷ +8 °C	668W
	-18 ÷ -22 °C	*935W

DOTAZIONE/Equipment

GRIGLIE Shelves	x3 GN 2/1 rilsan 650x530 mm
COPPIA GUIDE INOX Inox slides pair	x3 a "C"