

SPIRAL 46F



Utilizzabile per pasta all'uovo
For use with egg kneading



T.C.S. System
Tendicatena con molla di ripristino
T.C.S. System
Chain adjustment with restore spring



Timer
Timer



Doppia velocità
Double speed
3 Phase







Supporto con ruote disponibile
Available stand with wheels



Spezzapasta asportabile
Removable dough breaker bar



SCHEDA TECNICA A PAGINA 140
TECHNICAL SHEET ON PAGE 140

	DIMENSIONI INTERNE VASCA INTERNAL BOWL DIMENSIONS	
	Ø 500 x h.310 mm	
	CAPACITÀ VASCA BOWL CAPACITY	
	61 lt	
	IMBALLO CON PALLET PACKAGING WITH PALLET	
	l.1980 x p.600 x h.1010 mm	
	PESO NETTO NET WEIGHT	PESO LORDO GROSS WEIGHT
	150 kg	161 kg

	IMPASTO MASSIMO MAX KNEADING
	46 kg (farina/ flour max 32 kg)
	IMPASTO MINIMO MIN KNEADING
	14 kg

	PASTA ALL'UOVO FRESH EGG DOUGH
	32 kg

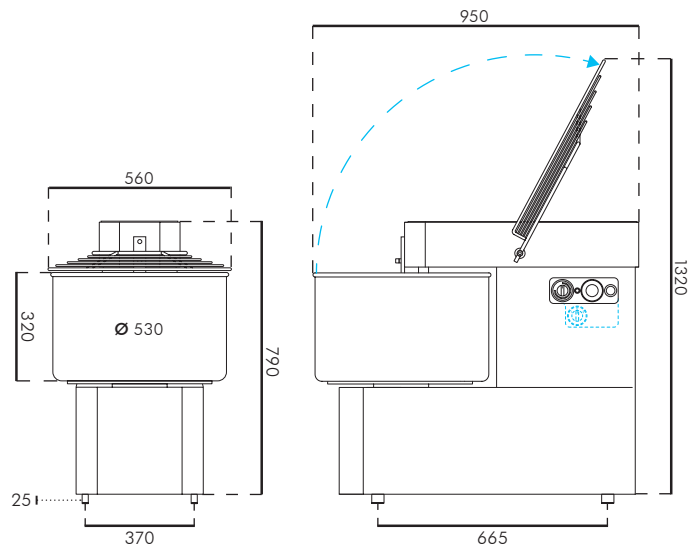

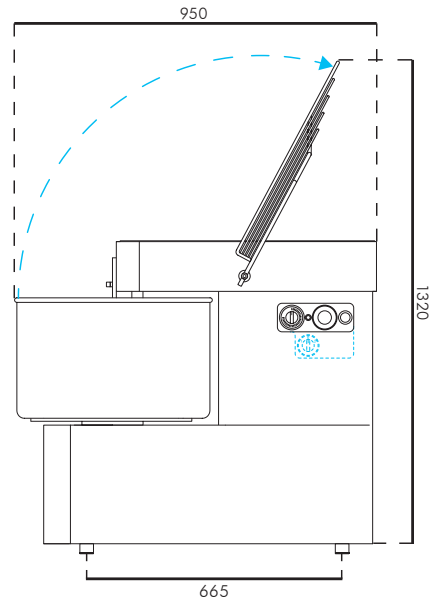
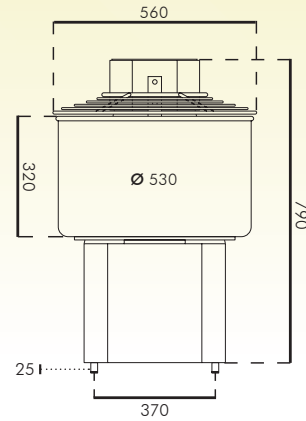
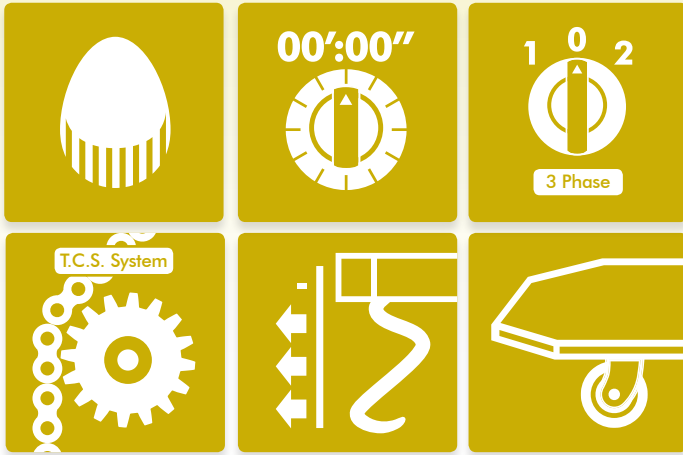

DIMENSIONI/Measures

VOLUME CON IMBALLO Volume with packaging	1.980 x p.600 x h.1010 mm
DIMENSIONI INTERNE VASCA Internal bowl dimensions	Ø 500 x h.310 mm
CAPACITÀ VASCA Bowl capacity	61 lt
PESO NETTO Net weight	150 Kg
PESO LORDO Gross weight	161 Kg

CARATTERISTICHE/Details

IDEALE PER PASTA ALL'UOVO Ideal for egg pasta	✓
T.C.S. SYSTEM TENDICATENA CON MOLLA DI RIPRISTINO T.C.S. System Chain adjustment with restore spring	✓
TIMER Timer	✓
DOPPIA VELOCITÀ Double speed	✓
CAVALLETTO CON RUOTE DISPONIBILE Available stand with wheels	✓
SPEZZAPASTA ASPORTABILE Removable dough breaker bar	✓

CAPACITÀ DI IMPASTO/Kneading capacity

IMPASTO MASSIMO Max kneading	46 kg (farina/ flour max 32 kg)	
IMPASTO MINIMO Max kneading	14 kg	
PASTA ALL'UOVO Fresh egg pasta	32 kg	
VELOCITÀ SPIRALE Spiral speed	UNA VELOCITÀ One speed	83 RPM
	DUE VELOCITÀ Two speeds	80-125 RPM
VELOCITÀ VASCA Bowl speed	UNA VELOCITÀ One speed	8 RPM
	DUE VELOCITÀ Two speeds	8-12 RPM

IMPIANTO ELETTRICO/Electric system

ALIMENTAZIONE Electrical supply	400V 3P+T/50 Hz	
	230V 3P+T/50 Hz	
	230V P+N+T/50 Hz	
POTENZA Power consumption	UNA VELOCITÀ One speed	1800 W
	DUE VELOCITÀ Two speeds	1800-2250 W