

PIZZA ROLLER 242



Trasmissione ad ingranaggi
Transmission gears



Comando a pedale
Footswitch pedal

Ø 26 ÷ 42 cm



SCHEDA TECNICA A PAGINA 148
TECHNICAL SHEET ON PAGE 148

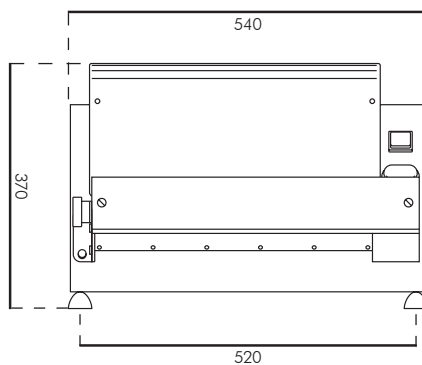
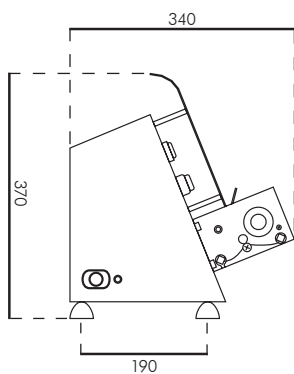

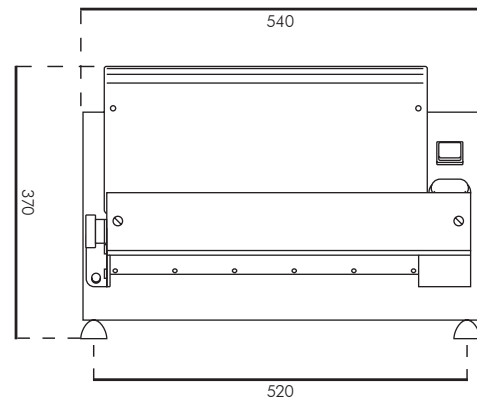
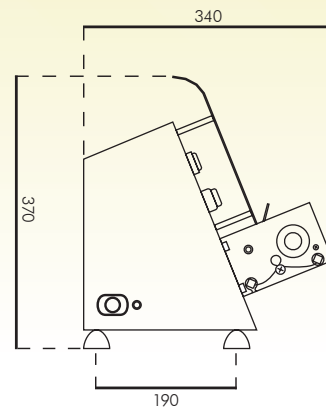
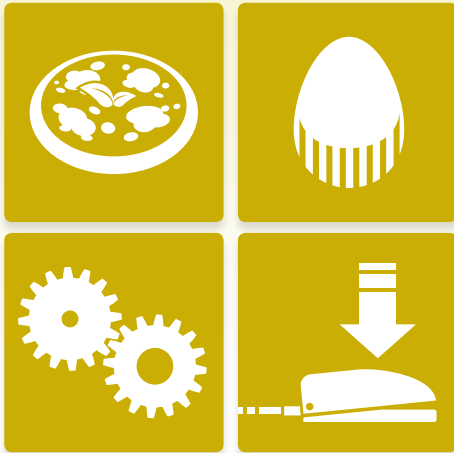
DIMENSIONI/Measures

VOLUME CON IMBALLO Volume with packaging	1.600 x p.400 x h.500 mm
DIMENSIONI Dimensions	1.540 x p.340 x h.370 mm
PESO NETTO Net weight	23 Kg
PESO LORDO Gross weight	27 Kg

CARATTERISTICHE/Details

PESO PASTA Knead quantity	210 > 700 gr
DIAMETRO PIZZA Pizza diameter	26 > 42 cm
SPESSORE PASTA Knead thickness	0,5 > 5 mm
VELOCITÀ Speeds	1/PULSE
TRASMISSIONE Transmission	Motoriduttore/ cinghia Gear reducer/ belt
COMANDO A PEDALE Foot switch	✓

IMPIANTO ELETTRICO/Electric system

ALIMENTAZIONE Electrical supply	230V P+N+T/50 Hz
POTENZA Power consumption	370 W