

FORK 30V



Ideale per pasta all'uovo
Ideal with egg knead



Timer
Timer







Variatore di velocità
Speed adjuster

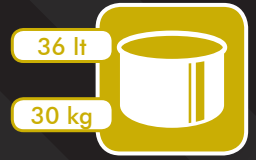

Supporto con ruote disponibile
Available stand with wheels



| | | |
|---|--|----------------------------|
|  | DIMENSIONI INTERNE VASCA INTERNAL BOWL DIMENSIONS | |
| | Ø 530 x h.220 mm | |
|  | CAPACITÀ VASCA BOWL CAPACITY | |
| | 36 lt | |
|  | IMBALLO CON PALLET PACKAGING WITH PALLET | |
| | l.1200 x p.800 x h.900 mm | |
|  | PESO NETTO NET WEIGHT | PESO LORDO GROSS WEIGHT |
| | 136 kg | 182 kg |

| | |
|---|---------------------------------|
|  | IMPASTO MASSIMO MAX KNEADING |
| | 30 kg (farina/ flour max 20 kg) |
|  | IMPASTO MINIMO MIN KNEADING |
| | 9 kg |

| | |
|---|-----------------------------------|
|  | PASTA ALL'UOVO FRESH EGG PASTA |
| | 9 kg > 30 kg |

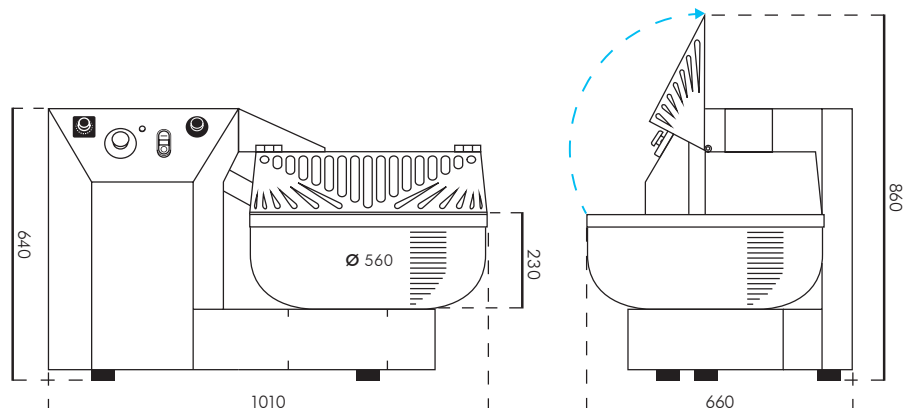

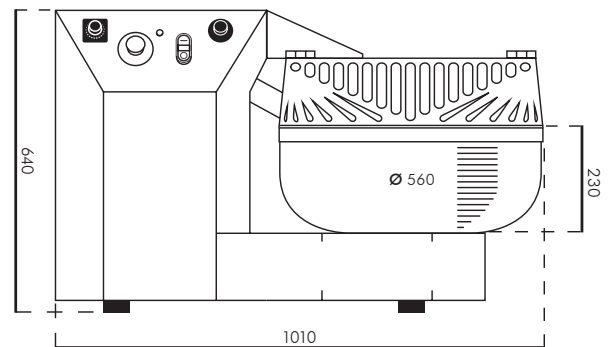
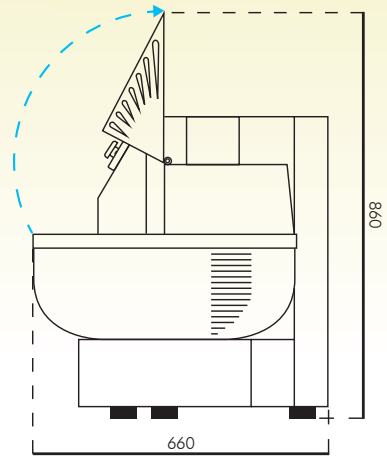

DIMENSIONI/Measures

| | |
|--|---------------------------|
| VOLUME CON IMBALLO Volume with packaging | 1.1200 x p.800 x h.900 mm |
| DIMENSIONI INTERNE VASCA Internal bowl dimensions | Ø 530 x h.220 mm |
| CAPACITÀ VASCA Bowl capacity | 36 lt |
| PESO NETTO Net weight | 136 Kg |
| PESO LORDO Gross weight | 182 Kg |

CARATTERISTICHE/Details

| | |
|---|---|
| IDEALE PER PASTA ALL'UOVO Ideal for egg pasta | ✓ |
| TIMER Timer | ✓ |
| VARIATORE DI VELOCITÀ Speed adjuster | ✓ |
| CAVALLETTO CON RUOTE DISPONIBILE Available stand with wheels | ✓ |

CAPACITÀ DI IMPASTO/Kneading capacity

| | |
|-----------------------------------|---------------------------------|
| IMPASTO MASSIMO Max kneading | 30 kg (farina/ flour max 20 kg) |
| IMPASTO MINIMO Min kneading | 9 kg |
| PASTA ALL'UOVO Fresh egg pasta | 9-30 kg |
| VELOCITÀ FORCELLA Spiral speed | 15 > 38 RPM |
| VELOCITÀ VASCA Bowl speed | 3 > 7 RPM |

IMPIANTO ELETTRICO/Electric system

| | |
|------------------------------------|------------------|
| ALIMENTAZIONE Electrical supply | 230V P+N+T/50 Hz |
| POTENZA Power consumption | 750 W |