

AKUTEK 35R



Realizzato in inox
Inox made



max h.203 mm



120"



2,77 kW

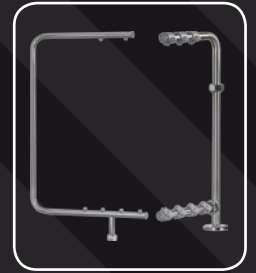

Cestello rotante
Rotating rack



Controllo carico acqua
Water load control



Porta coibentata
Insulated door



Pannello estraibile
Removable panel



Accessibilità anteriore
Front accessibility



SU TUTTI I MODELLI AKUTEK 35R

- Vasca a bordi raggiati
- Circuito risciacquo/lavaggio indipendenti
- Predisposizione dosatore detersivo con iniettore inox in vasca
- Dosatore brillantante
- Doppio filtro aspirazione
- Pompa lavaggio autopulente
- "RINSE OK", risciacquo garantito

ALL AKUTEK 35R MODELS EQUIPPED WITH

- Tank with rounded edges
- Rinsing and washing independent loops
- Built-in connection detergent dispenser, inox made
- Rinse aid dispenser
- Double aspiration filter
- Self cleaning washing pump
- "RINSE OK", assured rinsing

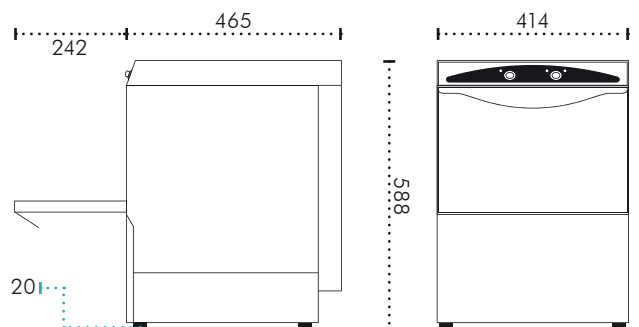



max h.203 mm

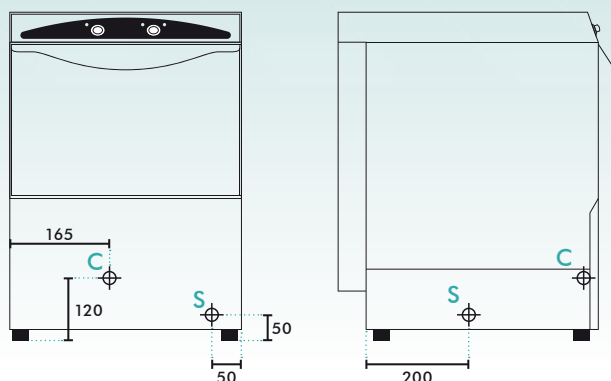

C: attacco tubo di carico
 S: attacco tubo di scarico
 C: water supply hose attachment
 S: water drain hose attachment

DIMENSIONI/Measures	
DIMENSIONI CON IMBALLO Packaging measures	570 x 550 x h.720 mm
VOLUME CON IMBALLO Volume with packaging	0,22 mc
PESO NETTO Net weight	25,5 kg
PESO LORDO Gross weight	32 kg
LUNGHEZZA TUBO DI CARICO Water supply hose, length	1400 mm
ATTACCO TUBO DI CARICO Water supply hose, attachment	3/4 gas
LUNGHEZZA TUBO DI SCARICO Water drain hose, length	1150 mm
DIAMETRO TUBO DI SCARICO Water drain hose, diameter	1" 3/4 (Ø 24 mm)
ALTEZZA SCARICO DA TERRA Water drain attachment, height from floor	50 mm

IMPIANTO ELETTRICO/Electric system	
ALIMENTAZIONE Electrical supply	230V P+N+T/50Hz
ASSORBIMENTO Power consumption	2,77 kW
RESISTENZA BOILER Boiler resistor	2,6 kW
RESISTENZA VASCA Tank resistor	1 kW
POMPA LAVAGGIO Wash pump power consumption	0,17 kW

IMPIANTO IDRAULICO/Hydraulic system	
CAPACITÀ VASCA Tank capacity	11,6 l
CAPACITÀ BOILER Boiler capacity	2,9 l
DUREZZA DELL'ACQUA Water hardness	8 F°
TEMPERATURA MASSIMA ACQUA D'INGRESSO Water input maximum temperature	55 C°
CONSUMO ACQUA PER CICLO Water consumption per cycle	2,4 l

PRODUZIONE/Working output	
PRODUZIONE CESTI ORARIA Working racks per hour	30
CICLO DI LAVORO Work cycle	120"
MICRO DI SICUREZZA A PORTA Safety door micro switch	✓
LIVELLO ACQUA AUTOMATICO Automatic water level	✓

DOTAZIONE/Equipment	
DOTAZIONE CESTI Racks equipment	x2
DIMENSIONI CESTO Rack measures	Ø 355 mm
CONTENITORE POSATE Cutlery case	x1